



Six series

Nano, Mini, Gamma, Delta,
Theta, Omega



Range of measurement, force

$\pm 36 \text{ N} \dots \pm 40000 \text{ N}$



Range of measurement, moment

$\pm 0.5 \text{ Nm} \dots \pm 6000 \text{ Nm}$

Application example

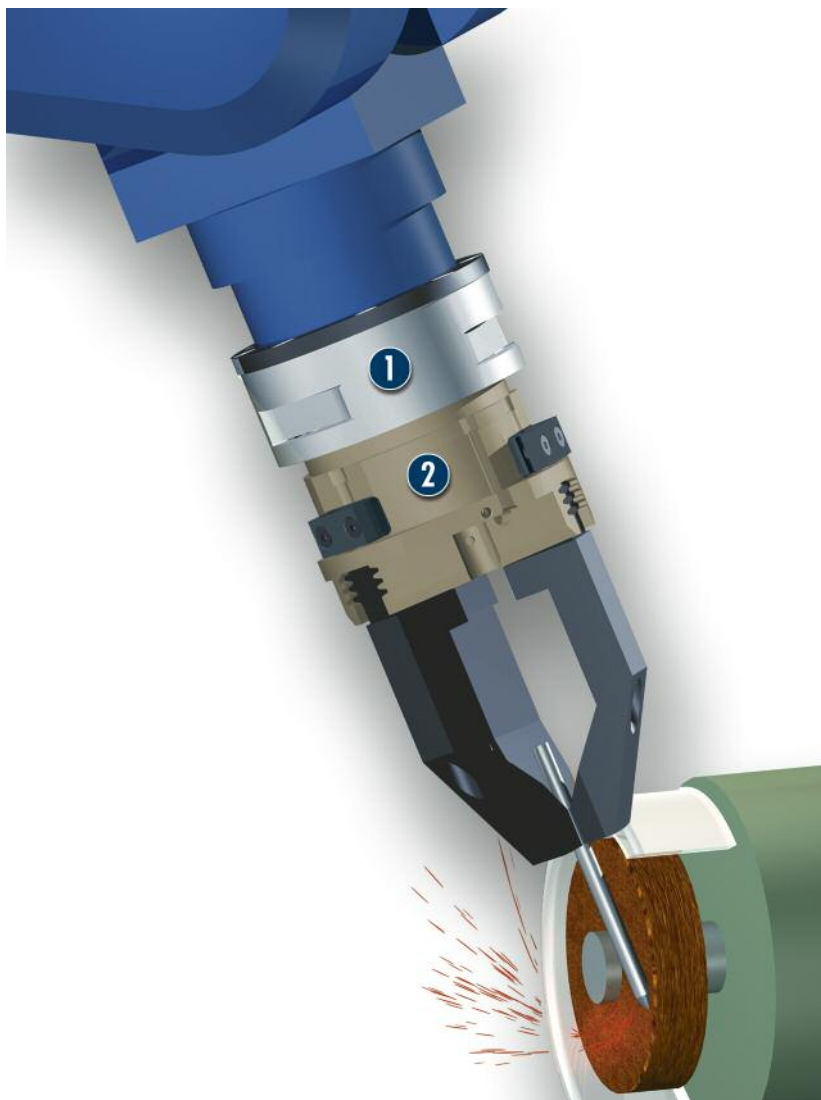

Robot-supported chamfering of round rods

- 1 FT-Delta 6-Axis Sensor
- 2 PZN-plus 64 3-Finger Centric Gripper

Force Sensor

6-axis sensor

Area of application

for precise measuring of forces and moments in all three spatial directions

Your advantages and benefits

Six sizes

with different ranges of measurement

High degree of resolution of measured values

and fast data transfer for virtually real-time force monitoring

Robust design

due to a higher overload range

Rotation and translation of the coordinates system

in all three directions

Robust design and easy to operate

for a long tool life and reduced set-up costs



General information on the sensor element

Working principle

Monolithic measuring element with three measurement harnesses at an angle of 120°. Each harness is fitted with two semiconductor strain gauge bridges which record the deformation in micrometers.

Overload protection

In all six axes, overloads to the values specified above are permitted without the sensor having to be recalibrated. Additional overload bolts protect the sensor from mechanical damage.

Material

Aluminum, stainless steel

Ambient temperature

0 °C to 70 °C, calibrated at 22 °C

Measuring accuracy

less than +/- 1% of the upper range value at 22 °C

Temperature compensation

Hardware side as standard

Splash protection

IP 65 on request

Warranty

12 months

FTD DAQ F/T system

The 6 axis force-torque sensor FTD is available in two different configurations, depending on the size of the sensor:

Sensor with integrated interface board

Delivered as standard:

- Sensor with interface board (from Gamma size)
- Sensor cable (10 m)
- Power supply box
- Connecting cable to the PC (2 m)

Sensor with external interface board

Delivered as standard:

- Sensor without interface board (sizes Nano and Mini)
- Sensor cable (1.8 m)
- Power supply box with integrated interface board
- Connecting cable to the PC (2 m)

Description of the individual components

6-axis force-torque sensor

Strain gauges (DMS) measure the strains applied in all six degrees of freedom (Fx, Fy, Fz, Tx, Ty and Tz). The DMS signals are amplified in the sensor. Because of the size, the interface board for the Nano and Mini series is not located in the sensor, but in the power supply box (IFPS).

Sensor cables

With the Nano and Mini sensors, the sensor cables are soldered into the sensor. A connector is located on the sensor housing of larger sensors to fix the sensor cable.

The highly-flexible sensor cable protects the sensor signals from electric fields and mechanical strains.

Interface board

The interface board converts the strain gauge signals into a signal which can be used by the DAQ card. To ensure optimum measurement results, the amplification factors are adjusted in line with the sensor used. The sensor and the interface board therefore form a single unit.

Power supply box

The power supply box contains the voltage transformer which converts the PC's 5 V power supply into a voltage which can be used by the sensor. In the Nano and Mini system the interface board is integrated into the box as well as the voltage transformer.

Connecting cable to the PC

The highly-flexible connecting cable carries the PC voltage to the power supply box and the sensor signals to the DAQ card.

Data acquisition card (DAQ)

The DAQ card converts the sensor's analog DMS signals into digital signals. DAQ cards are available for a wide variety of BUS systems (PCI, cPCI, PCMCIA, USB, ISA).

DAQ F/T system for Gamma and larger sensors

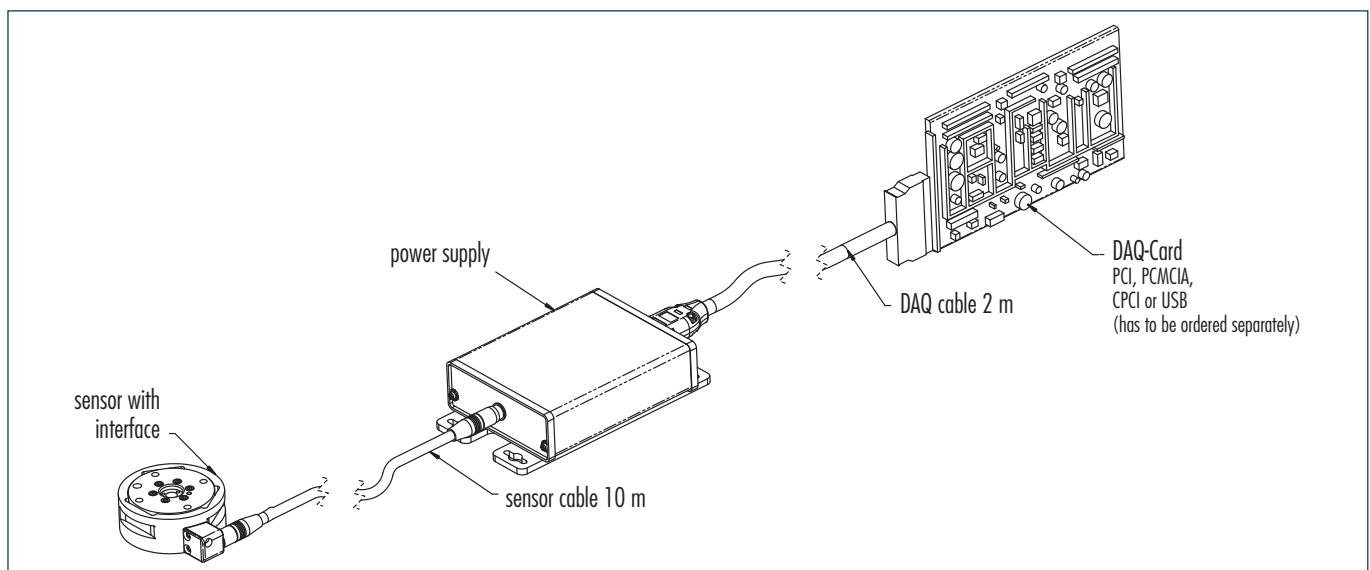

DAQ cards

The DAQ cards available for the sensor are shown in the list below. If you are already using DAQ hardware it could be used in differential or single-ended mode. We recommend differential-ended mode for an optimum, low-noise measurement signal.

Available DAQ cards

ID	Designation	Resolution	Bus	Max. transmission rate
0322005	FTD-DAQ-N1CPCI	16-bit	cPCI	14.2 K datasets/second
0322006	FTD-DAQ-N2CPCI	12-bit	cPCI	28.5 K datasets/second
0322003	FTD-DAQ-N1PCMCIA	16-bit	PCMCIA	28.5 K datasets/second
0322004	FTD-DAQ-N2PCMCIA	12-bit	PCMCIA	28.5 K datasets/second
0322011	FTD-DAQ-M1PCI	16-bit	PCI	250 K datasets/second

① The max. transmission rate is dependent upon the overall speed of the computer system.

The analog measurement values issued by the sensor are amplified strains from the strain gauges (DMS) and not forces and moments. The software provided converts the DMS signals into forces and moments. In order for the signals to be converted, all six DMS signals must be digitized by the DAQ card.

DAQ software

The DAQ F/T software provided contains Windows ActiveX components, a C library and an example program.

Software features

The automation server ATIDAQFT is a Windows ActiveX component which carries out the following functions:

- Importing the calibration file
- Configuring the sensor system
- Converting the sensor signals which are read in via the DAQ card into forces and moments
- Supporting tool transformation

The ATIDAQFT server has been developed for use in an ActiveX environment.

The following programs are examples of those supported.

- LabVIEW™, Microsoft Visual Basic™, Visual Basic for Applications and Visual C++™
- For other operating systems a C library is available with the same range of functions.

Demo program

The Windows DAQ F/T demo program provides visual and numerical representations of forces and moments. A Windows operating system (Windows 95 or later) is required. The Visual Basic 6.0 source code is used as an aid for creating additional application programs. A LabVIEW application program is currently being developed.

DAQ F/T system for Mini and Nano sensors

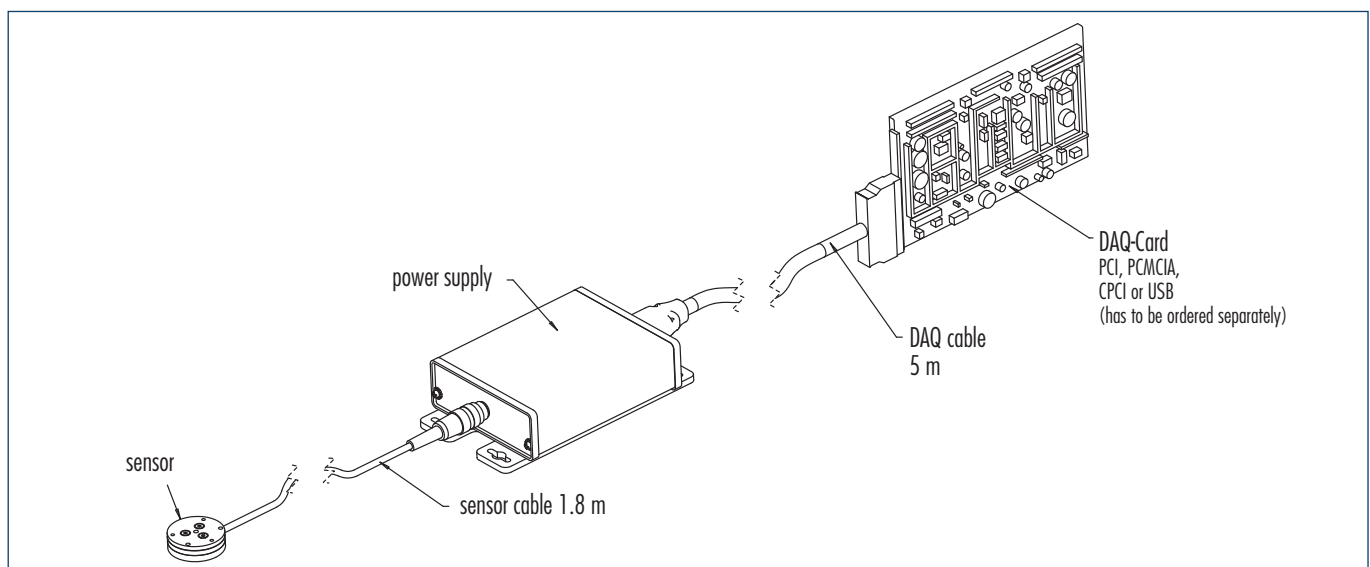

Stand alone controller, FTS version

The 6 axis force-torque sensor FTS is available in two different configurations, depending on the size of the sensor:

Sensor with integrated MULTIPLEX board

Delivered as standard:

- Sensor with MULTIPLEX board (from Gamma size)
- Sensor cable
- Stand alone controller
- Network cable

Sensor with external MULTIPLEX board

Delivered as standard:

- Sensor without MULTIPLEX board (sizes Nano and Mini)
- Sensor cable
- MULTIPLEX box
- MULTIPLEX cable
- Stand alone controller
- Network cable

Description of the individual components

6-axis force-torque sensor

Strain gauges (DMS) measure the strains applied in all six degrees of freedom (Fx, Fy, Fz, Tx, Ty and Tz). The DMS signals are prepared on the MULTIPLEX board. Because of the size, the MULTIPLEX board for the Nano and Mini series is not located in the sensor, but in the MULTIPLEX box.

Sensor cables

With the Nano and Mini sensors, the sensor cables are soldered into the sensor. A connector is mounted onto the sensor housing of larger sensors to fix the sensor cable. The highly-flexible sensor cable protects the sensor signals from electric fields and mechanical strains.

MULTIPLEX board

The MULTIPLEX board amplifies the strain gauge signals and issues them in multiplex form. To ensure optimum measurement results, the amplification factors are adjusted in line with the sensor used. The sensor and the MULTIPLEX board therefore form a single unit. With the Nano and Mini sensors, the MINI MULTIPLEX board is located in an extra box.

Stand alone controller

The stand alone controller is connected to the sensor or to the MULTIPLEX box. It converts the multiplex-form DMS signals into forces and moments. Functions such as tool transformation are implemented in the controller. Communication is carried out via an RS-232 interface. The force and moment measurement values are issued in the form of analog strains. Optically decoupled I/Os facilitate simple integration into the machine control system.

FTS system

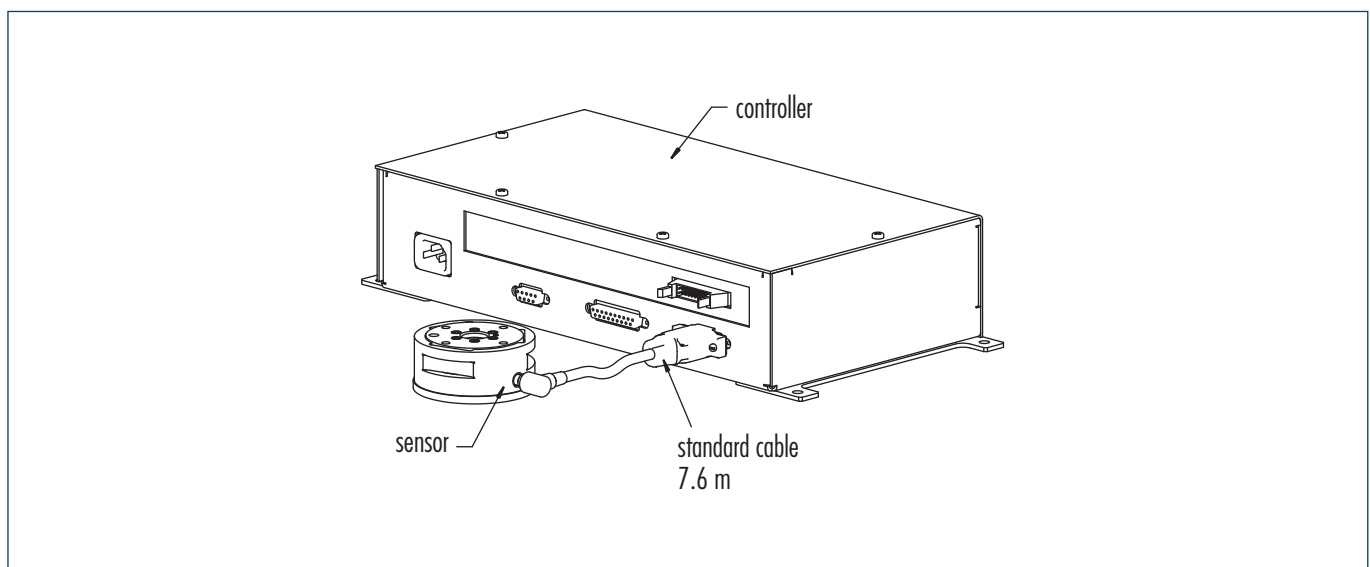

Sensor selection schematic

1. Calculating the expected forces and moments

The moment load is usually the determining factor when selecting a sensor. The tool weight and the application process generate the forces which can act upon the sensor in the form of moments. The moment is calculated from the force applied (static and dynamic) multiplied by the lever arm. The lever arm is calculated from the distance from the point of application of the force to the sensor's reference point. At the design stage, forces and moments which could act upon the sensor outside of normal operation also have to be taken into account.

2. Sensor pre-selection on the basis of the forces and moments

Please use the table below.

3. Determining the resolution

Check whether the sensor's resolution matches your requirements. It is possible that a sensor selected on the basis of the forces and moments does not meet the requirements with respect to resolution.

The basic principle is the larger the range of measurement, the lower the resolution.

Example

The maximum expected force acting on the sensor is 98 N (10 kg). This force acts on the sensor at a distance of 25 cm. The moment is therefore 24.5 Nm.

The FT-Delta-SI-330-30 is suitable for this application. (Range of measurement 330 N and 30 Nm). Overload safety is 230 Nm (M_{xy}).

Notes on robot applications

During a crash, extremely high forces and moments act on the sensor due to the robot's mass inertia and braking deceleration.

To protect the sensor in these situations, we recommend the use of an OPS or OPR collision and overload protection device.

Brief overview of FT

Designation		Nano	Nano	Nano	Mini	Mini	Gamma	Delta	Theta	Omega	Omega	Omega	Omega
		17	25	43	40	45				160	190	250	331
Max. F_{xy}	[\pm N]	50	250	36	80	580	130	660	2500	2500	7200	16000	40000
Max. M_{xy}	[\pm Nm]	0.5	6	0.5	4	20	10	60	400	400	1400	2000	6000
Weight	[kg]	0.01	0.07	0.04	0.05	0.09	0.25	0.91	4.99	2.72	6.35	30.0	43.0
Diameter	[mm]	17	25	43	40	45	75.4	94.5	155	156	190	254	254
Height	[mm]	14.5	21.6	11.5	12.3	15.7	33.3	33.3	61.1	55.9	55.9	95	107



How to order FTS sensors with stand-alone control

FTS-[sensor]-(cable) - □ - □ - □ - □

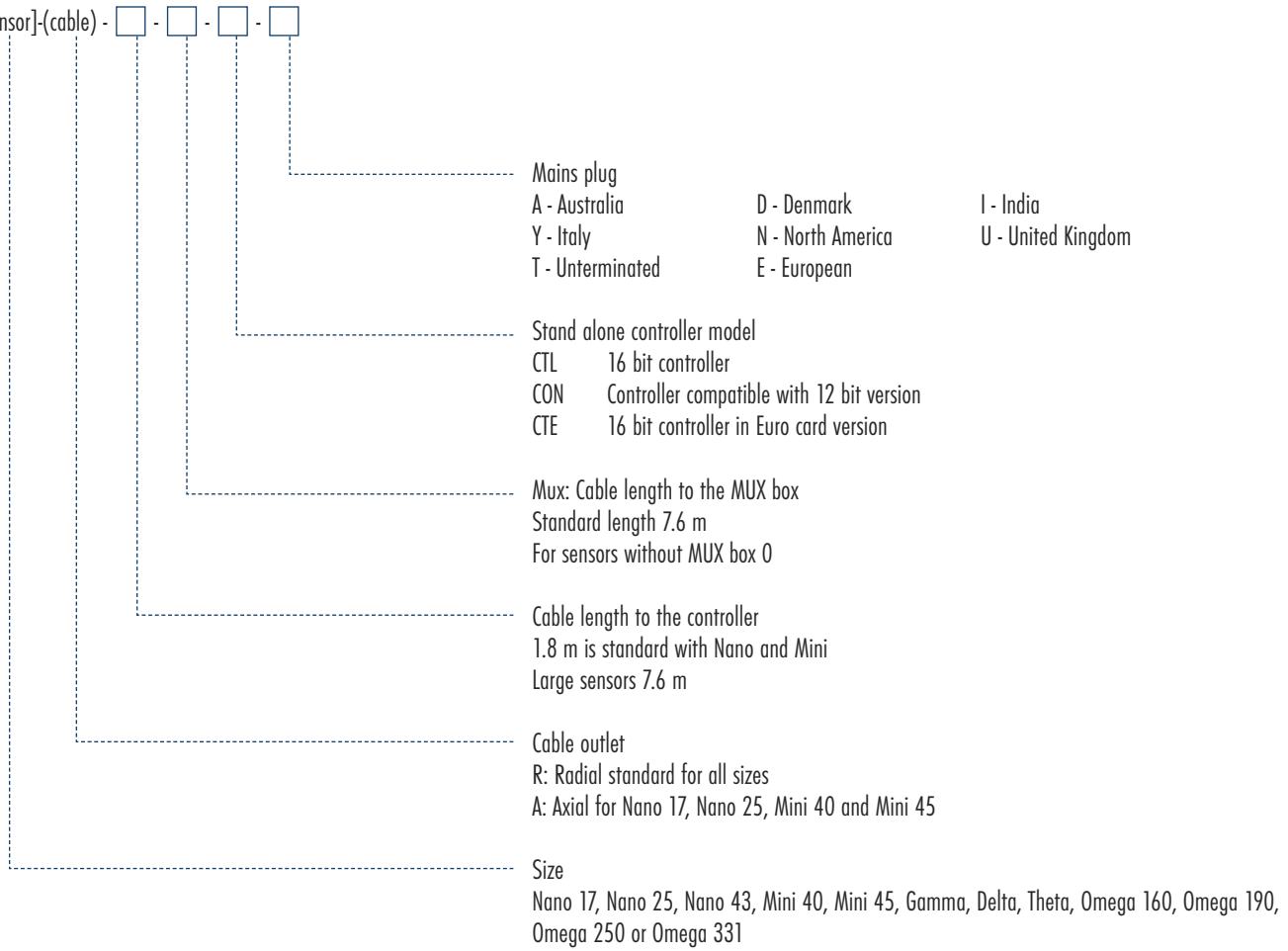

How to order FTD sensors

FTD-[sensor]-(cable) - □ - □ - □

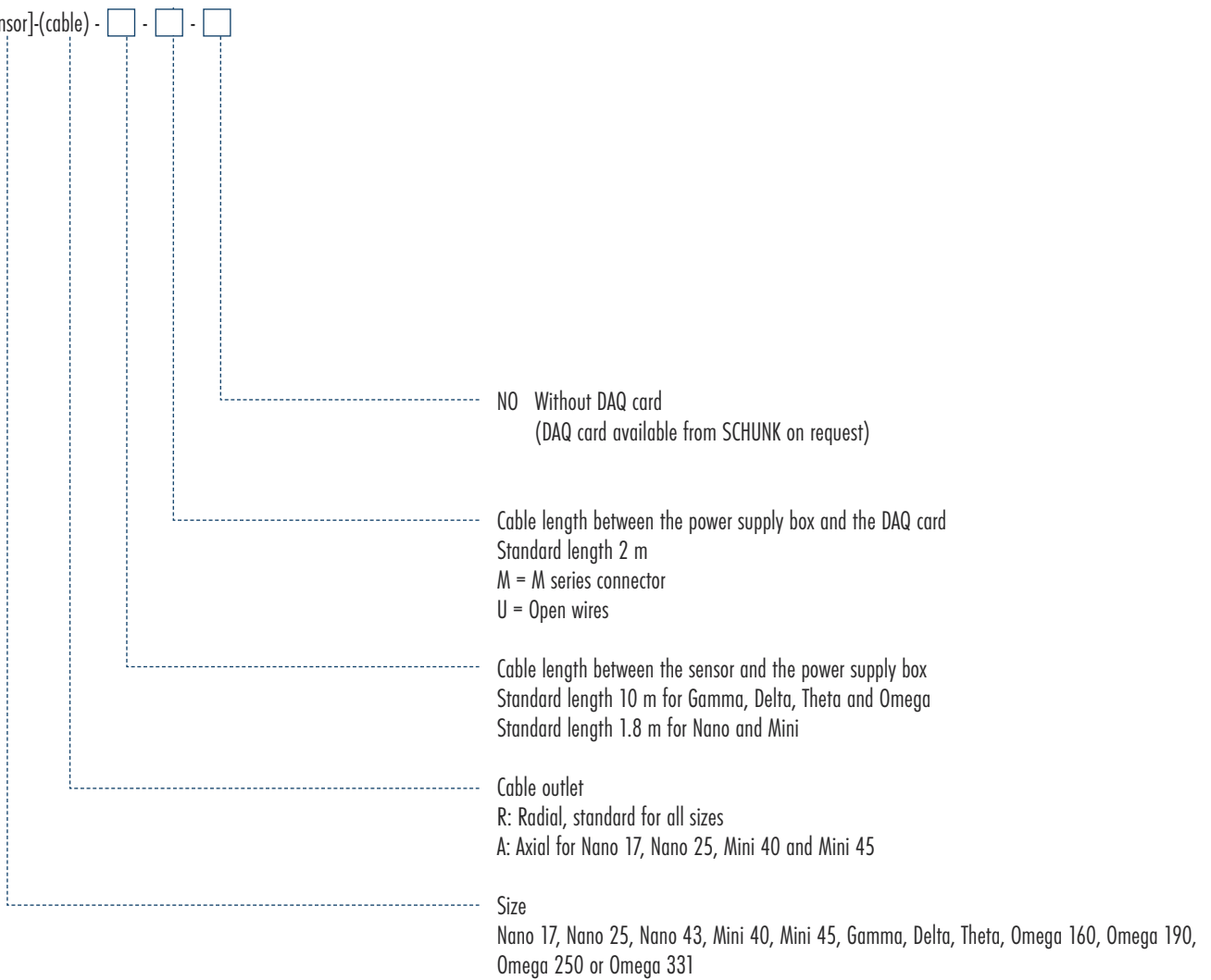



Product advantages

- Wire eroded measuring element made from high-strength, stainless steel
- Special overload bolts make the Delta an extremely robust transducer
- Up to 148-fold overload safety with respect to the range of measurement

Measurement signal resistant to interference due to use of silicium strain gauges

Silicium strain gauges provide a signal which is 75 times stronger than conventional foil strain gauges. The silicium strain gauges reduce signal noise to practically nothing.

Sensor also available in the following protection classes

- IP 60 dust-proof version
 - IP 65 splash-proof version, suitable for use in damp environments
 - IP 68 immersion-proof version down to 10 m
- For further information or drawings please feel free to contact us. We will be happy to help.

Typical areas of application

- Real-time force monitoring
- Robot set-up
- Haptics investigations
- Rehabilitation research

Technical data

Designation	FTS-Delta	FTD-Delta	FTS-Delta	FTD-Delta	FTS-Delta	FTD-Delta
Calibration	SI-165-15	SI-165-15	SI-330-30	SI-330-30	SI-660-60	SI-660-60
Resolution	Stand alone	DAQ	Stand alone	DAQ	Stand alone	DAQ
Mass [g]	913	913	913	913	913	913
Range of measurement, F_x, F_y [N]	± 165	± 165	± 330	± 330	± 660	± 660
Range of measurement, F_z [N]	± 495	± 495	± 990	± 990	± 1980	± 1980
Range of measurement, M_x, M_y [Nm]	± 15	± 15	± 30	± 30	± 60	± 60
Range of measurement, M_z [Nm]	± 15	± 15	± 30	± 30	± 60	± 60
Resolution, F_x, F_y [N]	± 1/16	± 1/128	± 1/8	± 1/64	± 1/4	± 1/32
Resolution, F_z [N]	± 1/8	± 1/64	± 1/4	± 1/32	± 1/2	± 1/16
Resolution, M_x, M_y [N]	± 1/264	± 1/2112	± 3/400	± 3/3200	± 3/200	± 1/1600
Resolution, M_z [Nm]	± 1/264	± 1/2112	± 3/400	± 3/3200	± 3/200	± 1/1600
Overload, F_{xy} [N]	± 3500	± 3500	± 3500	± 3500	± 3500	± 3500
Overload, F_z [N]	± 11900	± 11900	± 11900	± 11900	± 11900	± 11900
Overload, T_{xy} [Nm]	± 230	± 230	± 230	± 230	± 230	± 230
Overload, T_z [Nm]	± 420	± 420	± 420	± 420	± 420	± 420
Rigidity, force XY axis (KF_x, KF_y) [N/m]	37×10^6	37×10^6	37×10^6	37×10^6	37×10^6	37×10^6
Rigidity, Z axis (KF_z) [N/m]	61×10^6	61×10^6	61×10^6	61×10^6	61×10^6	61×10^6
Rigidity, force XY axis (KM_x, KM_y) [Nm/rad]	52×10^3	52×10^3	52×10^3	52×10^3	52×10^3	52×10^3
Rigidity, Z axis (KM_z) [Nm/rad]	94×10^3	94×10^3	94×10^3	94×10^3	94×10^3	94×10^3
Resonance, frequency F_x, F_y, M_z [KHz]	1.5	1.5	1.5	1.5	1.5	1.5
Resonance, frequency F_z, M_x, M_y [KHz]	1.7	1.7	1.7	1.7	1.7	1.7

Main views

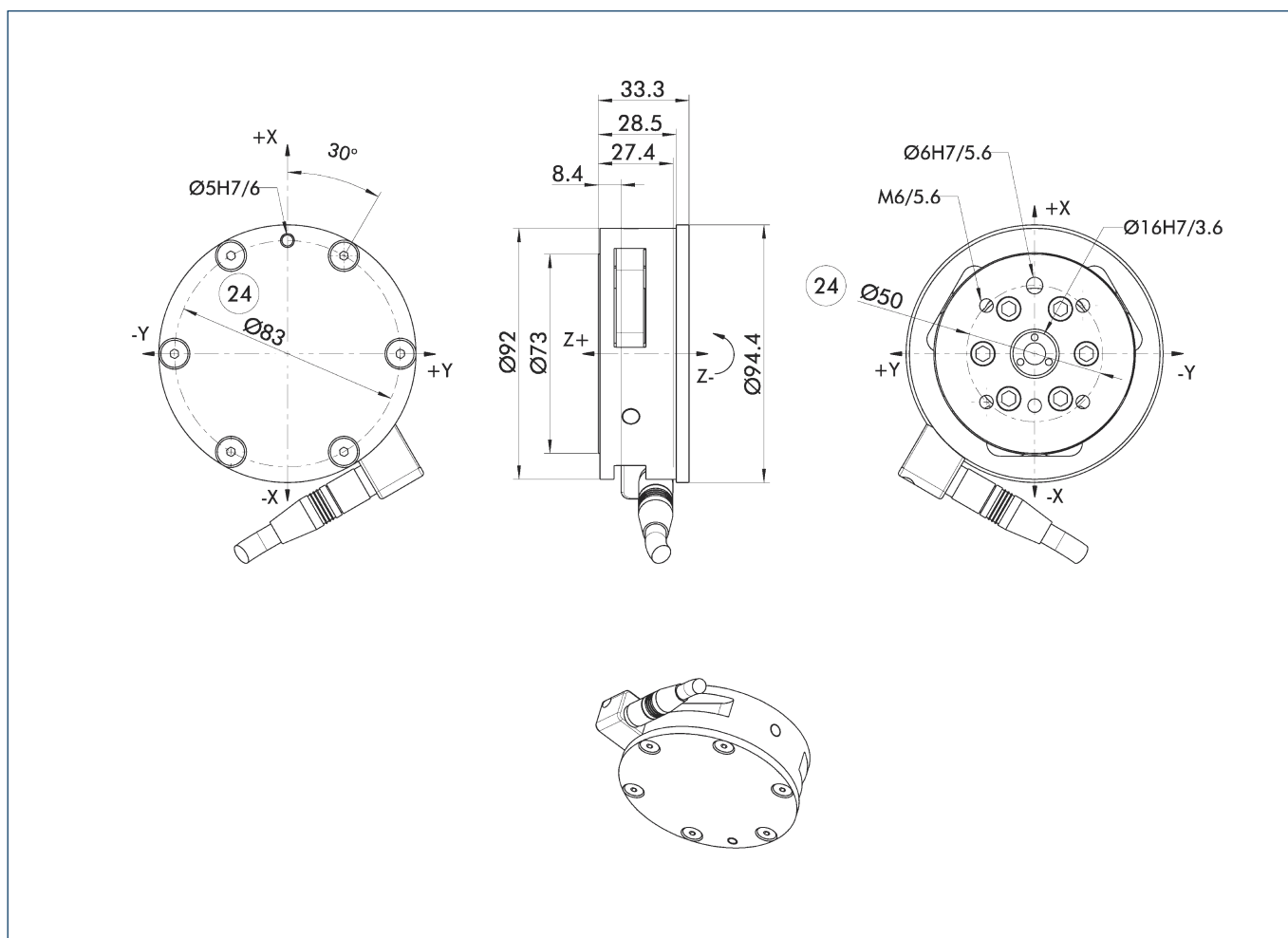

24 Bolt pitch circle